

UF | GETS THE JOB DONE.

The powerful utensil washer



One machine for perfect cleanliness and hygiene. Perfectly coordinated accessories. Specially developed chemicals. Advice and personal support. Planning expertise and training courses. Monitoring, reporting and service. All that and more from Winterhalter.



UF-L

UF-M

UF-XL

Neat and tidy: the UF-XL has an extra compartment for the chemicals canister.



FULL POWER.

This is the real test for a warewasher. Extremely stubborn soiling. On a variety of utensils. When washing becomes a challenge, the UF Series from Winterhalter is in its element. Robust design. With immense power. And innovative features: for excellent wash results and maximum hygiene. Are you a baker, butcher or caterer who washes utensils in extreme conditions? The UF is your machine.

MACHINE SIZES

Perfectly adapted to your utensils: the UF is available in three different sizes. The compact UF-M is ideal for smaller and medium-sized utensils. The UF-L has additional entry height that allows even large baking trays to be washed. And the UF-XL has sufficient capacity for large and bulky utensils.

FIRST-CLASS WASH RESULTS

Whether it's proteins, starch or grease: the UF deals with even extremely heavy and stubborn soiling. Its high-performance washing system and a soaking programme make it your professional solution for washing utensils.

CERTIFIED HYGIENE SAFETY

Wherever food is being worked with, hygiene standards apply. The UF ensures that you can flawlessly comply with these: with consistent standards for certified hygiene safety according to DIN SPEC 10534.

SIMPLE TO USE

Touch screen and quick-start button. Fold-back door. Rack dolly and swing rack. These and many other features make operation of the UF easy, intuitive and ergonomic.

ABSOLUTELY RELIABLE

Washing utensils under extreme conditions. The UF Series is specially designed for this: the high-quality materials and solid finish make the machine robust, absolutely reliable and extremely durable. You can rely 100% on your UF.

THE PERFECT UTENSIL WASHER.

Various utensils. In various industries. With various requirements. But always with the same aim: a professional warewashing solution. Precisely tailored to the individual situation. The UF Series from Winterhalter makes this possible.

BUTCHER'S SHOPS / MEAT MARKETS

The heaviest soiling. Particularly from grease and proteins. On everything that is used in production: tools, utensils and boxes. And on everything that is used in the shop: knives, chopping boards and display trays. In butcher's shops, markets and abattoirs, warewashing is particularly important. In the UF Series, Winterhalter has developed a professional warewashing solution for this industry: guaranteeing first-class cleanliness and absolute hygiene that is easy to operate and inexpensive to run. And it can be tailored precisely to the requirements of butcher's shops and markets.



»The UF is the all-terrain vehicle of commercial warewashers: a robust design and a solid finish, with extremely high wash pressure and absolute reliability in every situation. Bring it on.«

Manuel Kreibich,
PRODUCT MANAGER INTERNATIONAL



BAKERIES / CONFECTIONERS

Baking trays with burnt-on residues. Dried dough residue on a wide range of utensils. Display trays sticky with icing. Baking is where everything comes together: different dishes, different materials, different types of soiling. Bakeries and confectioners demand the highest washing performance. Manual cleaning is too tedious, time-consuming and does not provide adequate hygiene safety. The solution is the UF Series from Winterhalter: It delivers first-class wash results in the shortest possible time – even with stubborn deposits. Resource-friendly, cost-effective and reliable.



FOODSERVICE

Bulky kitchen tools and utensils. Heavily soiled pots and pans. Baked-on trays and greasy bowls. And other utensils used throughout the day. The challenge: everything needs to be perfectly clean as quickly as possible. Foodservice presents special challenges when it comes to washing up. In addition to continuous operation and peak times, there is also a large number of different items to be washed. And Winterhalter has the perfect solution for these: the UF Series utensil washers. For hygienic cleanliness – even for large wash items with stubborn stains.



Utensil rack with insert for bakery boxes



Utensil rack with insert for cake rings



Utensil rack with insert for trays



A detailed overview of the UF Series is available on our website at:

>> www.winterhalter.com/uf

HIGH-PERFORMANCE WASHING SYSTEM

Every UF comes with a stainless steel high-performance washing system as standard: the special geometry of the wash arm and a water pressure of up to 1 bar guarantee optimal cleaning performance throughout the entire interior of the machine. The VarioPower variable wash pressure adjustment ensures that the wash pressure is adapted to the degree of soiling of the wash items. The result: perfectly washed utensils and maximum hygiene.

FOLD-BACK DOOR

With the UF Series utensil washers, it's not just washing that runs smoothly. Cleaning the interior of the machine is also a breeze: the optional fold-back door can be unlocked and simply folded down. This means there is nothing in the way, and the interior of the machine is easily accessible.

SOAKING PROGRAMME

Sometimes washing can be very difficult: in these cases, dried or baked-on dirt should be soaked first. The standard UF soaking programme takes care of this: before the actual wash cycle, the wash items are soaked with the tank water. This helps to release stubborn dirt effectively – and eliminates the need for a manual pre-wash.

CONNECTED WASH

Digitalisation is creating new opportunities in the field of commercial warewashing and improving both safety and efficiency. With CONNECTED WASH, UF Series machines can be integrated into your network and all the important operating data can be evaluated. Consequently, recommendations and actions are made that will help to optimise the washing process. The machine status can be monitored from anywhere in the world through the free app. A further advantage: in the event of a critical error, CONNECTED WASH automatically sends a notification to a defined group of recipients. As well, the UF automatically receives all important updates, keeping its software always up to date.

HEAT RECOVERY

Intelligent use of energy: as an option, the UF can be fitted with integrated Energy circulating air heat recovery. This uses the energy from the hot steam to pre-heat the cold inlet water. This significantly reduces energy consumption, lowers operating costs and ensures that hardly any steam escapes when the machine is opened.

RACK DOLLY

Ergonomic. Practical. Uncomplicated. With a rack dolly, which is available as an accessory, bulky and heavy wash items can be collected quickly and transported to the machine with ease. Once there, the rack is simply pushed directly from the dolly into the machine. And after washing, everything can be sorted and put away just as quickly. For optimal workflow in the kitchen.

WARM WATER INITIAL FILL

For a fast machine start: the UF can optionally be configured so that the tank is filled directly with warm water. This means the UF is ready for operation more quickly and consumes less energy. Of course, the same applies when changing the tank water in the course of a washing day.

COLD WATER PRE-WASH

Anyone who works with proteins and starch will know: it's important to pre-wash with cold water to avoid baking the dirt onto the wash items. All UF Series utensil washers can be equipped with cold water pre-washing as an option. Clean, cold water releases the dirt before the actual wash cycle begins. This guarantees a hygienically clean wash result and reduces the work involved in manual pre-washing.



»As a cooking school, we have specific requirements for a warewasher. It has to be quick so we lose as little time as possible during courses. It must be suitable for bulky baking sheets and large cooking pots. And it also has to reliably remove stubborn leftovers – as our pupils burn things from time to time. The UF does this brilliantly. And to top it all off, it's really easy to use!«

Małgorzata Michalska, OWNER OF THE ASHANTI INTERNATIONAL COOKING SCHOOL | ŁÓDŹ, POLAND

Note: the product illustrations are customer-specific configurations that may also include products from other manufacturers.

Cleanliness and hygiene. Every single one of our products plays its part. Together they create the perfect wash result. Welcome to the complete Winterhalter system!

UTENSIL RACKS AND RACK ACCESSORIES

Pots and bowls. Kitchen utensils. Equipment. The utensil racks from Winterhalter have been specially developed for bulky wash items. They are extremely strong and, thanks to their open stainless steel design, allow maximum water permeability. Special sliders make it easy to insert and remove the racks – which is particularly useful for heavy wash items. Whatever you are washing: there is a customised rack for your UF.

But Winterhalter not only has the right rack system for every application. The special accessories turn every rack into a completely individual solution. For bakeries, there are special inserts for cake rings and piping bags. For butcher's shops, there are inserts for chopping boards and meat boxes. And with an additional intermediate shelf, you can double the capacity easily.

Washing racks and rack accessories protect your wash items and deliver first-class wash results and fast drying. We will be happy to advise you on which racks best suit your requirements. Culminating in the best solution for you.



WATER TREATMENT

Trays, utensils, containers. Many of them made from delicate materials. Nearly all of them with heavy soiling. Washing utensils really is a tough job. There's a simple rule here: as effective as necessary, as gentle as possible.

Washers from Winterhalter achieve this balancing act in combination with the right water treatment devices: they reduce the mineral content in hard water and deliver consistently soft water. This offers several simultaneous advantages: smaller amounts of detergent and rinse aid are needed to do their job effectively. Better wash results ensure maximum hygiene. And the machine is continuously protected from harmful limescale deposits.



CHEMICALS

Washing is essentially about two things: perfect cleanliness and maximum hygiene. Chemicals have a decisive influence on both. This is the reason they are an important component of the overall Winterhalter system.

Many years ago at our German headquarters, we therefore established a research and development department with an in-house laboratory. Here we develop and test formulae for a premium range of detergents and hygiene products. These are precisely tailored to the different wash items and types of contaminants, economical to use, and they can be ideally combined with other products in our range. They work together perfectly and deliver first-class wash results.

SPECIALLY DESIGNED FOR UTENSIL WASHING

Proteins, starch, grease. Burnt on and encrusted. Washing utensils represents a particular challenge for a warewasher. The UF Series from Winterhalter is ideally equipped for this. The standard soaking programme ensures, that dried and baked-on dirt is softened and released before the actual wash cycle begins.

For the very toughest jobs, the UF is available with the special TurboZyme soaking process. This involves soaking the wash items with the special Crust Cracker chemical before the actual wash cycle begins, in order to release stubborn dirt effectively. This ensures an optimal wash result, even in the toughest of cases, and simultaneously saves time and effort: manual pre-washing becomes easier and can even be left out altogether.



ADVICE AND SERVICE

Winterhalter is the specialist in commercial warewashing systems. Our knowledge encompasses the widest range of kitchens in the world. We know which aspects are important when it comes to washing, and what has to be taken into consideration. And: we enjoy passing this knowledge and experience on to our customers.

The aim: a perfect washing process. Behind every UF Series warewasher are the high Winterhalter standards for a complete solution for your washing process. How can the warewashing system be adapted precisely to your available space and work processes? Which optional accessories make sense for your applications? What options are there for optimising your workflow? We help you answer every single question. So that you can make the right choices for your investment.

Your partner, Winterhalter. Our team of advisers and planners analyse your individual on-site conditions: the layout, the room arrangement, the processes. We plan your requirements and calculate the necessary equipment. We help you organise your washing operation, optimise the washing logistics and provide instruction and training sessions for your employees. And, of course, we take care of all the service and maintenance work – so that your machine can operate for as long as possible and you do not experience any downtime. In short: when it comes to washing, we're always there for you. From the start. And we help you to make your washing process as professional and efficient as possible.

What can we do for you? Let's talk about it: Tel. +49 7542 402-5408 or www.winterhalter.com/contact

»We are family people!«

Down-to-earth. Forward-looking. With a focus on family. The culture and values of our family have shaped the Winterhalter company for three generations. Close to staff, customers and partners. Long-term thinking with a view to the generations to come. Taking personal responsibility – all typically Winterhalter. We are proud of our family company. And we are pleased to grow a little more every day.



Karl Winterhalter



Jürgen Winterhalter



Ralph Winterhalter

THE FIRST WINTERHALTER



It all began in 1947: Karl Winterhalter established his own company in Friedrichshafen. He started by salvaging scrap metal from the war, which he used to manufacture household goods. Cooking pots and ovens, for example. A short time later he specialised, and in 1957 launched the GS 60 model: the first commercial warewasher from Winterhalter. That was the starting signal. Since then the company has always pursued a single goal: perfect wash results as part of an efficient washing process. With this holistic approach, Winterhalter has developed from a machine supplier to the full system provider of warewashing solutions it is today.

»Products, advice, service – three factors that intertwine seamlessly at Winterhalter. And that makes our customers feel safe in the knowledge that they have the right partner for any issue relating to the washing process.«

FROM WAREWASHER TO WAREWASHING SOLUTION

In days gone by, all we needed to do was deliver the new warewasher to our customer's kitchen on a hand truck. Now it's about the development of a new, individual warewashing solution, which is perfectly coordinated with the on-site situation and the special requirements and preferences of the customer. A solution of this type is based on clear analysis and planning. To achieve this, we visualise the room layout using state-of-the-art CAD software in 2D and 3D. For a bespoke and efficient washing process.



OVER 2.000

EMPLOYEES WORLDWIDE

High quality standards. Diligence. Curiosity and ambition. These are the typical attributes of a Winterhalter employee. And with them, we have grown from a small Swabian family company into a global player: with over 40 branches worldwide and distribution partners in over 70 countries. We are proud of what we have achieved. And we are proud of each and every employee who has done their bit. So we would just like to take this opportunity to officially say »Thank you!«



OUR ACADEMY OF WASHING SCIENCE

Almost 1,000 participants per year and 250 training days worldwide: as part of our training programmes we pass on our knowledge and experience in the discipline of »warewashing«. We provide training to our own personnel as well as to our retail and service partners. Our objective: every Winterhalter customer should receive informed advice and professional support in the specific situation. Whether it's an initial informative discussion, installing a warewasher, or service and maintenance appointments.

IN-HOUSE LABORATORY FOR IMPROVED CHEMICALS

As a specialist in warewashing, do we want to rely on the products of other manufacturers? The answer to this question was an immediate and resounding »No!«. This was the moment, when our in-house research and development laboratory was born: we have been developing our own formulas for original Winterhalter chemicals for many years now, from detergents and rinse aids to hygiene products.

Good to know

As a specialist in warewashing, at Winterhalter we set high standards for ourselves: we don't just want to meet our customers' current requirements. We want to support them proactively and gain their trust for the long term. Service plays an important role here: our comprehensive network guarantees fast and professional support on site. Worldwide.

We and our service partners are there when you need us. On that you can always rely with Winterhalter.



What opportunities does new technology offer? How is our society and the world of work changing? Which trends and developments will shape commercial warewashing in the future? We find all of these questions extremely exciting. And that's why we are already working on developments that will affect us and our customers tomorrow, and the day after that. You can take a look at the solutions that we have developed in our NEXT LEVEL SOLUTIONS. Current examples include CONNECTED WASH and PAY PER WASH.

>> www.connected-wash.com >> www.pay-per-wash.com

»See you again soon!«

Customers often own a Winterhalter warewasher for 15 or 20 years. So our customers only have to worry about disposing of their old equipment once every few decades. What's more, we take care of this ourselves. We design our machines as modular systems, so they are easy to dismantle if ever the need arises. We reduce the range of materials, use standardised construction materials and label plastic parts for easy recycling. Winterhalter warewashers have a particularly high recycling ratio thanks to these and many other measures.



MADE IN GERMANY AND SWITZERLAND

As ever, it is not simply an indication of origin, but a seal of quality: products made in Germany and Switzerland are recognised worldwide for their premium quality and reliability. For engineering, inventiveness and precision. Winterhalter is the best proof of this: in Meckenbeuren, Edingen and Rüthi, we develop and produce solutions for first-class cleanliness and hygiene. This is our promise for every single warewasher that leaves our factory.

GENERAL TECHNICAL DATA: UF SERIES

UF-M

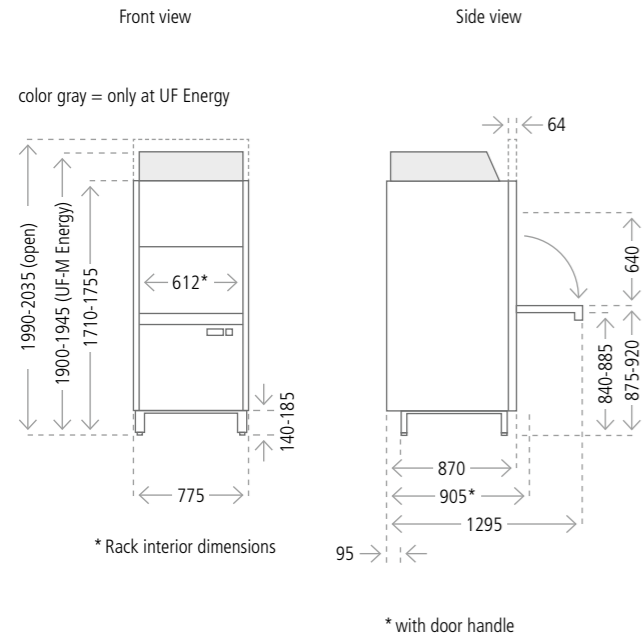

UF-L

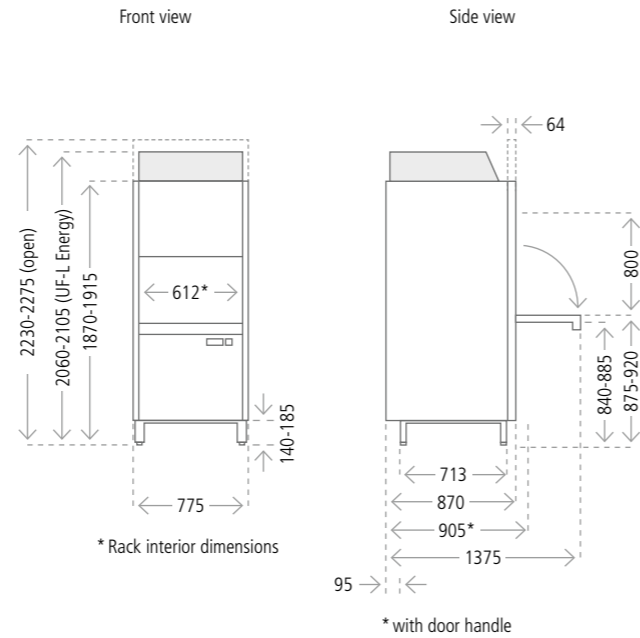

UF-XL

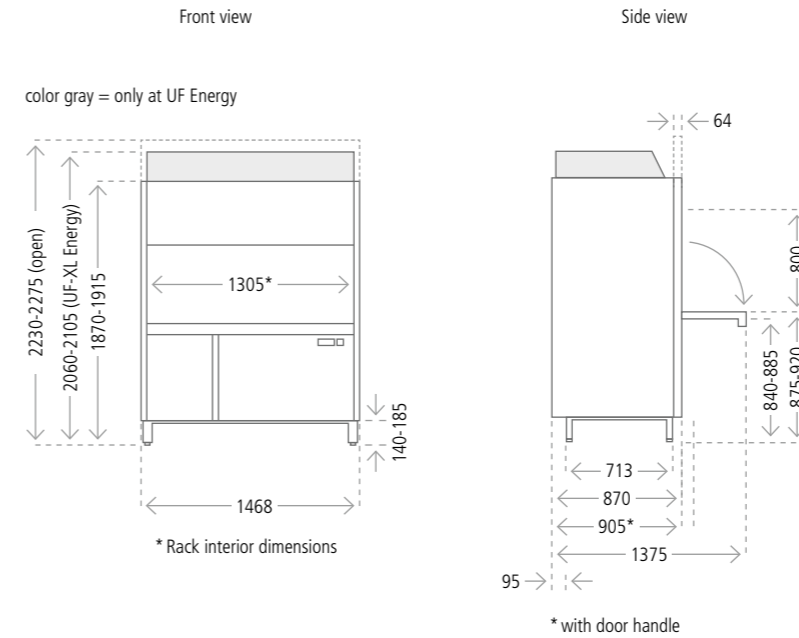

General data		UF-M	UF-L	UF-XL
Tank capacity	l	69	69	138
Rack interior dimensions	mm	612x672	612x672	1305x672
Clear entry height	mm	640	800	800
Wash pump	kW	2.5	2.5	2x2.5
Noise emission	dB(A)		< 70	
IP protection class			IPX5	
Weight net/gross	kg	190/220	200/230	305/355
Weight with Energy version net/gross	kg	225/255	235/265	350/400
Max. inlet water temperature	°C		60 (Energy: 20)	
Required water flow pressure	bar / kPa		1 – 10 / 100 – 1.000	
Required water flow pressure with Energy *1	bar / kPa		1,5 – 10 / 150 – 1.000	
Specific data				
Theoretical capacity standard *2	Racks/h		12/24/40	
Theoretical capacity short programme *2	Racks/h		23/42/64	
Theoretical capacity HighTemp *3	Racks/h		10/15/20	
Rinse water volume per wash cycle *4	l	4.7	4.7	7.0
Rinse water volume per wash cycle HighTemp *4	l	5.5	5.5	9.0
Tank temperature	°C		63	
Tank temperature HighTemp	°C		66	
Rinse temperature	°C		85	

ELECTRICAL DATA

Voltage	Fuse protection	Total connected load Standard		Total connected load Performance		Countries
		UF-M/L	UF-XL	UF-M/L	UF-XL	
380V, 3 N~, 50 Hz/60 Hz	16A	8.7 kW	8.4 kW	–	–	Worldwide
	20A	9.4 kW	8.8 kW	–	–	
	25A	10.0 kW	10.0 kW	–	–	
	32A	16.3 kW	16.2 kW	16.4 kW	16.4 kW	
400V, 3 N~, 50 Hz/60 Hz	32A	17.5 kW	17.4 kW	18.8 kW	18.8 kW	Worldwide
	40A	–	–	25.1 kW	26.2 kW	
	16A	10.0 kW	9.5 kW	–	–	
	20A	10.8 kW	10.8 kW	–	–	
415V, 3 N~ 50 Hz/60 Hz	25A	17.4 kW	17.1 kW	17.7 kW	17.7 kW	Worldwide
	32A	18.7 kW	18.4 kW	20.3 kW	20.3 kW	
	40A	–	21.1 kW	25.5 kW	26.8 kW	
	25A	9.4 kW	8.7 kW	–	–	
230V, 3~, 50 Hz/60 Hz	32A	10.2 kW	9.9 kW	–	–	Belgium
	40A	–	–	15.2 kW	15.1 kW	
	50A	–	–	17.7 kW	17.6 kW	
200V, 3~ 50 Hz/60 Hz	25A	7.6 kW	9.1 kW	–	–	Japan
	32A	9.0 kW	–	10.3 kW	10.3 kW	
	40A	–	–	12.2 kW	12.9 kW	
	50A	–	–	15.9 kW	16.8 kW	

*1 Inlet water temperature < 20 °C.

*2 Depending on local conditions (inlet water temperature / electrical supply), the values stated here may be reduced.

*3 Minimum 25A fuse protection, tank and boiler heating performance.

*4 Non-binding information. The actual rinse water volume may vary depending on the on-site conditions.

*5 The actual power varies depending on the mains voltage.

SOLUTIONS FOR WASHING UTENSILS:

THE SMALLEST UTENSIL WASHER IN THE WORLD.

Small kitchens. Cramped counters. Rooms with limited space. In places that seem to have little room for washing up, the world's smallest utensil washer comes into its own: the GS 630 takes up hardly any space and, as an undercounter version, it will also fit under a counter. It's easy to use, and washes quickly, economically and efficiently. In bakeries and butcher's shops. In the foodservice and chain restaurants. And it packs quite a punch: with its high water pressure, it cleans away even stubborn dirt, leaving your utensils hygienically clean. No matter what comes its way. Trays, GN containers, Euronorm crates. Trays and filters. The GS 630 guarantees perfect wash results. Small but mighty.



»Compact, flexible, efficient. The successful GS 630 concept is simple and has been impressing our customers worldwide for many years. We're proud of it!«

Manuel Kreibich, PRODUCT MANAGER INTERNATIONAL



PERFECT CLEANLINESS AND HYGIENE

Wherever utensils are in use, cleanliness and hygiene are the top priority. In the GS 630, a reversing wash system works with a wash arm at top and bottom. They follow one quickly after the other in opposite directions, thereby achieving maximum coverage and mechanical effect. This also ensures perfect wash results even with heavy soiling.

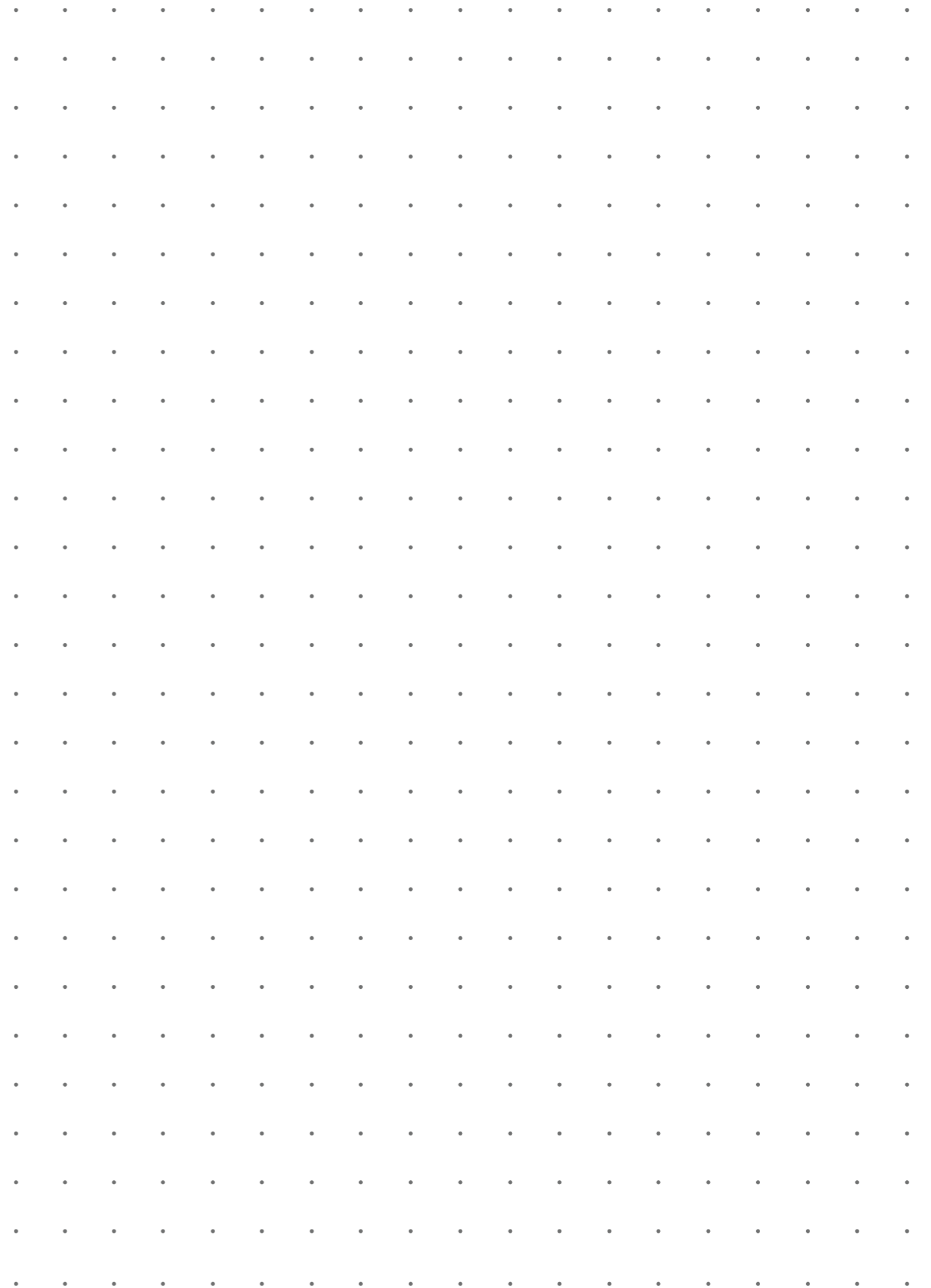

»In this brochure, we have presented our UF Series: its product features, application options and what sets it apart. However, we were not able to provide you with the strongest argument of all here: the positive experiences of our satisfied customers. Just ask next time you see a UF anywhere. There is no better aid to making your decision.«

Jürgen and Ralph Winterhalter